

Improving the Design of Arterial Blood Pressure Monitor

Alyona Skorobogatova, Anastasiya Sutyagina, Aleksei Anisimov
 Saint-Petersburg Electrotechnical University "LETI"
 Saint-Petersburg, Russia
 alena_969696@bk.ru, nsutyagina@gmail.com, aaanisimov@etu.ru

Abstract—This paper present the implementation of a blood pressure monitor which provides taking measurements during inflation of the arm cuff. Brief overview of functions of modern BPM is given. Methods of blood pressure measuring are shown. Block diagram of a device is pictured and the operation principle of blood pressure monitor is described. Signal filtering and amplification stage is suggested. Neural networks algorithm is presented. Using this algorithm for signal processing affords getting results with sufficient precision.

I. INTRODUCTION

Blood pressure (BP) is one of the most common parameter to measure in clinical practice which can provide significant information about physiological condition of subject and show the state of cardiovascular system. Thus, considerable deviations of this parameter from the norm could lead to serious heart diseases, stroke, retinal detachment [1-4]. When the blood pressure in the arteries is persistently elevated it is a pathology which is called hypertension (HT). The risk of cardiovascular system damaging depends on the value of BP. The higher blood pressure - the greater risk of damage of the heart and blood vessels in basic organs such as brain or kidneys. Hypertension is the cause of 12.8% of deaths around the world [1]. Among various types of hypertension particular attention should be paid to pregnancy-induced hypertension, which occurs in more than 10% of pregnancies and still remains one of the major health problems in this area [2-3]. Pregnancy-induced hypertension may be associated with pre-eclampsia, which is dangerous for both the mother and the baby [2].

Severely low blood pressure can also be life-threatening. The brain and other vital organs could be deprived of oxygen and nutrients, leading to a condition called shock. A survey in case of symptoms such as headache, weakness or dizziness often begins with blood pressure measurement. Many diseases requires constant monitoring of BP, when it is necessary to take measurements several times a day. Therefore, it is important to be very thoughtful when choosing the method of measuring BP and pay attention to its accuracy for proper identification of possible abnormalities. Despite the great achievements of modern medical technologies in the field of blood pressure monitors (BPM) the problem of belated detection of abnormalities in the human cardiovascular system remains topical. So, this paper represents a design of a BPM measuring blood pressure when inflating air to the cuff. This

solution will prevent excessive air inflation, re-inflation and ensure optimum pressure value in the cuff for each measurement, which guarantees a high measuring accuracy.

II. METHODS OF BLOOD PRESSURE MEASURING

There are two ways to measure the blood pressure:

- 1) Invasive (direct).
- 2) Non-invasive (indirect bloodless).

Invasive method is considered as the most accurate one [14]. It is implemented by placing a cannula needle in an artery (usually radial). However, this method is not applicable at home and may be applied only during cardiovascular (heart) surgery.

The most usual non-invasive method is to use an occlusive arm cuff. When an arm cuff is wrapped around the arm and air is being inflated to it, the blood flow through the artery is becoming disrupted. Two basic ways to determine blood pressure using arm cuff are following:

- 1) By evaluating character of changes in the blood flow, the BP parameters can be found (auscultatory method of Korotkoff).
- 2) By measuring some parameters which depend on the BP and calculating BP using known relations (oscillometric, palpation, and other methods).

In modern BPM (devices for non-invasive blood pressure measurement) auscultatory and oscillometric methods are usually used. When using auscultatory method (method of Korotkoff sounds) the cuff is placed on the patient's upper arm, air is being inflated, blood flow in the artery under the cuff completely stops (if we try to measure heart rate below the cuff, it is not "tapped"). Thereafter, as the air is being gradually deflated from the cuff, the blood flow begins to return to normal, accompanying by sounds of "tapping" called Korotkoff sounds. The appearance of these sounds is associated with the violation of the laminar blood flow and the occurrence of turbulent flow due to the increased cross-sectional area after passing the occluded area. The first clear "tapping" sound is defined as the systolic pressure (maximum pressure value). Sounds are changing in character until they completely disappear. The last audible sound is defined as the diastolic pressure (minimum pressure value). Fig. 1 shows implementation of Korotkoff sounds method.

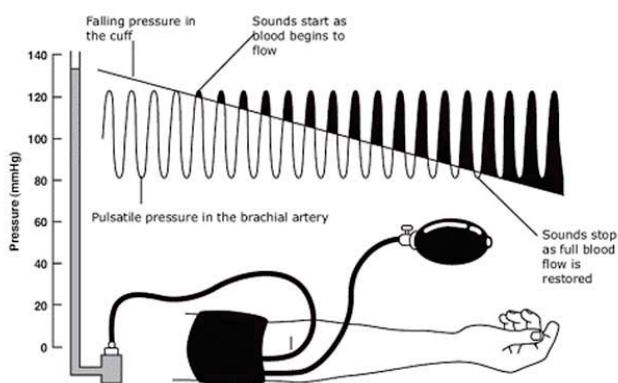

Fig. 1. The method of Korotkoff sounds

However, sounds can occur when pressure drops below the diastolic pressure, for some patients Korotkoff sounds cannot even be heard due to the features of their body because of various pathologies. Thereby, there are some disadvantages of an auscultatory method:

- Sensitivity to noise in the room.
- The requirement of direct contact of the head collar and microphone to the patient's skin.

This method is used mainly in the mechanical and semi-automatic BPM. In the automatic BPM the oscillometric method is applied. It is similar to the auscultatory method, but instead of Korotkoff sounds pressure pulsations relating to the turbulent flow of blood through the vessel are used for measuring BP. Pressure sensor connected to the tube detects pressure oscillations in the cuff as well as constant level of pressure. Fig. 2 shows the relationship between the method of Korotkoff (sound waves) and oscillometric method (pulsations in the cuff pressure oscillations).

There are different types of blood pressure monitors (BPM) on the market today: mechanical, semi-automatic and automatic. The most popular among the BPM for home use are automatic BPM as they are easy to use. BPM capabilities analysis shows that the majority of devices operate in the air-inflating phase. The main functions of modern BPM are listed below.

- Determination of systolic (SBP) and diastolic (DBP) blood pressure.
- Heart rate calculation.
- The intelligent control technology to avoid excessive arm occlusion when device «listening» heart rate like a doctor and in the absence of pulse, it begins the deflating phase.
- Indication of arrhythmias. This function is achieved by analyzing pressure oscillations (pulse wave) and monitoring heart rate.
- Motion display. The necessity of this function is caused by sensitivity of the oscillometric method to the patient's movements during measurements which can

significantly distort the resulting data, so in the case of such notification (e.g. on the LCD) measurement is advised to be repeated.

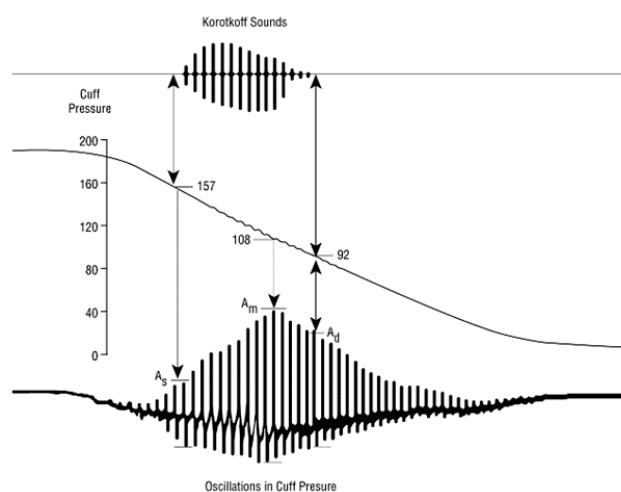

Fig. 2. The relationship between the method of Korotkoff and oscillometric method

Maintaining patient's diary using conventional BPM is possible only with the paper, when the patient writes down the date, time, and the corresponding values of SBP and DBP by himself and then can consult with a doctor showing collected data. With the development of telemetry this approach is becoming more and more uncomfortable, so nowadays has begun to appear BPM having the ability to connect wirelessly to PC or smartphone via Bluetooth. Such kind of BPM are not very widespread and the available models sometimes do not provide enough accuracy, but BPM with wireless connection capability have unique features which are not presented in conventional automatic devices such as:

- Exchanging data with PC or smartphone.
- Collection of measurement statistics, ability to analyze gathered data.
- Displaying visual trends and charts.

III. BLOOD PRESSURE MONITOR IMPLEMENTATION

Using gathered data about BPM, necessary requirements and considering the disadvantages of modern BPM, we have worked out the device taking measurements during air inflation. Fig. 3 shows a block diagram of the designed BPM.

Air pump, arm cuff, pressure sensor, mechanical valve to release air from the cuff and electromagnetic (EM) valve to remove extra air from it after measurements are connected to each other via hollow tube, which make it possible to the air to circulate between all the components of the system.

MOSFET analog switches control EM valve and air pump. The pressure sensor detects pressure variations in the arm cuff and issues a voltage proportional to the input pressure. Since sensor output signal consists of a constant component (cuff pressure) and a variable component (pulse wave), it is necessary to identify the pulsations on the background of a constant component. For this purpose, the pressure sensor is

directly connected to the amplification stage consisting of three first order RC passive type filters, one buffer circuit and one non-inverting amplifier.

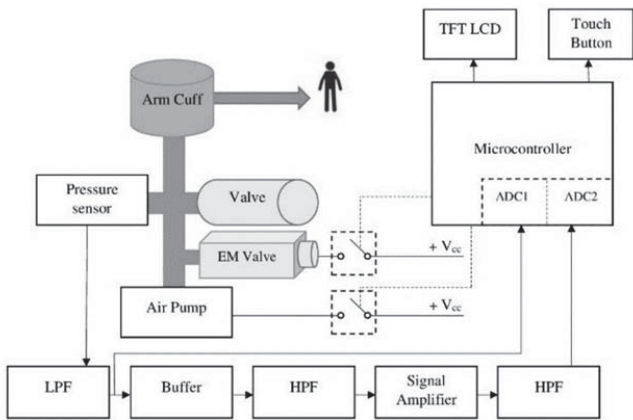

Fig. 3. The block diagram of blood pressure monitor

First, a signal is passed through a 10 Hz low-pass filter (LPF) in order to remove high-frequency noise. Then the signal goes through a buffer circuit consisting of a single Op-Amp in buffer mode to couple the signal to the sensor and then it goes to the built into microcontroller (MC) analog-to-digital converter (ADC) to take the arterial pressure measurements. The signal is then filtered again with a 2.2 Hz RC high-pass filter (HPF) which gets a cleaner signal for amplification and amplified using a non-inverting amplifier composed by a second Op-Amp and two resistors. After this stage, the signal is filtered once more with another 10 Hz RC LPF. The pulsations are recorded at the amplification stage output and digitized by the ADC.

IV. SIGNAL PROCESSING

At first, measurements were taken during air deflating. Fig. 4 shows corresponding pulse wave curve. When an electromagnetic valve controls the deflation of the air from the arm cuff, step by step, air quickly leaves the cuff due to a rapid opening of the valve (which can only work through regulating by a switch without the possibility of smooth adjustment) and cuff pressure decreases too fast. In addition, there are transients because of opening and closing EM valve, so specific peaks occur on pressure oscillations graph after signal filtering (differentiation). It makes the signal unfit for further processing. Therefore, it is better to use a mechanical (uncontrolled) valve with a small diameter outlet.

The cuff pressure oscillations that have been obtained using the mechanical valve are shown in Fig. 5. After getting curves describing pulse wave when air is being deflated from the cuff, measurements of BP have been made during air inflating. Fig. 6 shows the corresponding curve.

Since receiving necessary signals, they are subjected to the following processing steps:

A. *Digital filtering with LPF and HPF to get the informative part of the signal and remove noise.*

Filtration is performed using high-pass digital filter (2-order IIR filter with 0.5 Hz cut-off frequency) and low-pass

digital filter (4-order IIR Butterworth filter with 7 Hz cut-off frequency). It should be noted that the first 1.5 seconds of signal are removed before filtration, as they are associated with the occurrence of transients. Fig. 7 shows the resulting curves.

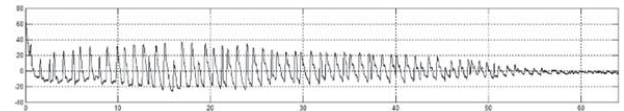

Fig. 4. The pulse wave curve registered during air deflating

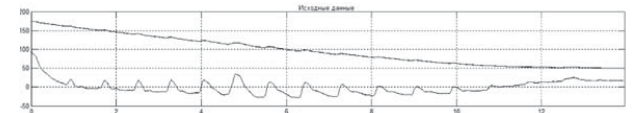

Fig. 5. Cuff pressure vs. pressure oscillations (air deflating)

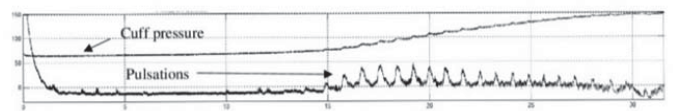

Fig. 6. Cuff pressure vs. pressure oscillations (air inflating)

B. *Identifying local maximums of the curve representing pressure oscillations.*

To do this, the needed curve is differentiated, then the appeared high-frequency components are removed from the resulting signal. The described filtering procedure is carried out using a low-pass Butterworth filter 2 order with 5 Hz cut-off frequency. Then, filtered and differentiated signal is squared for amplification of the informative components and suppression the non-informative (related to noise) ones. After that, signal is amplified with approximately 500-700 gain (since the amplitude of differentiated signal is significantly lower than the amplitude of pulse wave) and the threshold is indicated intersection of which shows a local maximum of the signal. Fig. 8 shows the method.

C. *Finding the envelope function.*

According to the points of local maximums can be found the envelope function using a cubic spline. With these envelope functions values of mean arterial pressure (MAP), systolic and diastolic blood pressure can be determined via the maximum amplitude algorithm (MAA).

D. *Determining the distance between the standing nearby peaks t_{peak} and calculating the heart rate using following equation:*

$$HR = 60 / t_{peak}$$

After signal pre-processing the values of blood pressure parameters (SBP, DBP and MAP) can be calculated. The main and most popular method of finding the SBP and DBP is the MAA [5]. This method is based on detecting the point corresponding to mean arterial pressure (defined as maximum of the envelope function) on the oscillation curve. To compute values of SBP and DBP, it is necessary to multiply the MAP

pulsation amplitude by an index that vary among different medical equipment developers (SBP index ranges from 0.45 to 0.73, DBP – from 0.69 to 0.83). Fig. 9 represents the MAA.

Implementing this algorithm to signals registered with designed BPM we have found the curve of pressure pulsations and points corresponding to SBP and DBP. Fig. 10 shows the results.

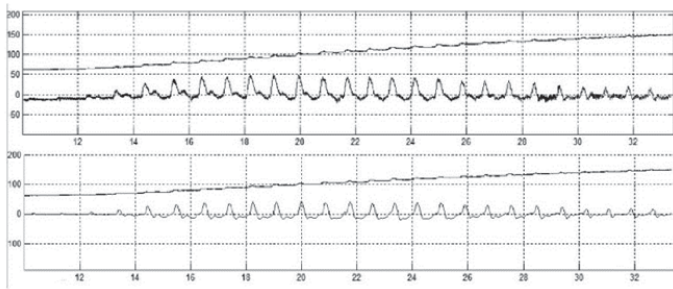

Fig. 7. The curves of filtered signals

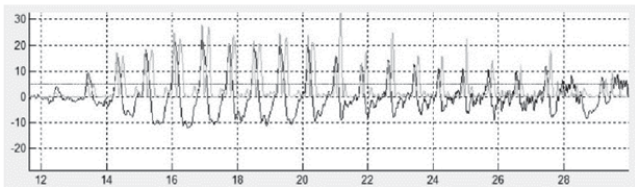

Fig. 8. Identifying local maximums of the curve representing pulse wave

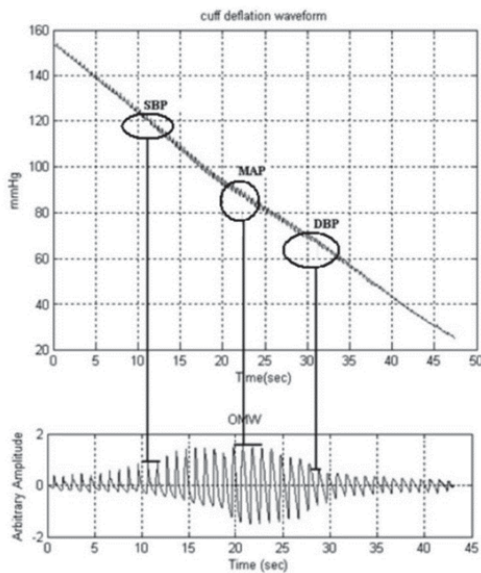

Fig. 9. The maximum amplitude algorithm

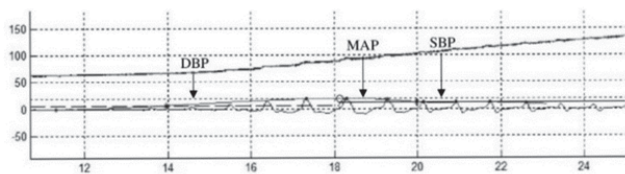

Fig. 10. The results of applying maximum amplitude algorithm to signal registered via designed blood pressure monitor

If we represent the whole algorithm of signal processing as block diagram we will get the picture shown in Fig.11.

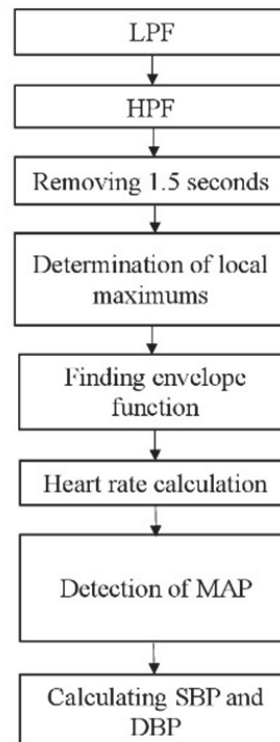

Fig. 11. The block diagram of signal processing algorithm

V. NEURAL NETWORKS

In [7] it was shown that the MAP value can be accurately obtained by MAA. However, due to the sensitivity of the method to changes in blood pressure pulsations SBP and DBP cannot be determined with sufficient accuracy. In addition, it appears that the MAA is not able to determine systolic and diastolic blood pressure when relationship between blood pressure and pressure pulsations in the cuff is not linear. A possible solution is to use an algorithm called neural networks (NN) instead of MAA for signal processing. NN do not require an exact mathematical model, so it is useful for physiological systems which are not easy to model due to their non-linear nature.

There are NN which help to analyze pressure oscillations in the cuff and determine the value of BP (dual-layer and three-layer NN). In [8] – [10] BP pulsations was used as input signals. Slow air deflation from the cuff allowed to get quite smooth curves, but in the case of presence of artifacts it was difficult to process them (errors were removed and were not involved in the further processing). These networks have some drawbacks [11]:

- NN performance depends on input data that it receives (redundant data degrade efficiency of the network).
- Large number of data leads to creation of NN with huge quantity of input nodes (the more input nodes – the

more hidden nodes to determine the exact output values are required) [12].

Since collecting large number of data is quite time-consuming and requires significant use of means, it is possible to represent a signal in contracted form (e.g., using most significant components) [11]. The idea consists in elimination components with a low level of dispersion (signal of pressure oscillations in the cuff can be represented as sum of two Gaussian functions).

The steps of this method are described below (Fig. 12 shows the process):

- Getting the curve of pressure oscillations.
- Filtering.
- Determination of extremums of the curve.
- Mapping the highs and lows points of interpolating functions.
- Finding the absolute signal of pressure oscillations (ASPO) (calculated as the difference between maximums and minimums).
- Approximation the ASPO with two Gaussian functions and minimizing the standard deviation.
- Normalizing the resulting function.
- Creation of the NN.

Described method made it possible to reduce errors and size of the network, but it works properly only when the ASPO is close to the normal distribution. If the ASPO is not satisfy this condition, an algorithm that can adapt to the shape of ASPO curve is needed. NN algorithm can be used to create such an algorithm in MATLAB software environment. As input values for NN is used data array consisting of 10 local maximums involving pressure values and time corresponding to them. Thus, an array 1*30 is created (values obtained for 10 patients). Seven from ten arrays are used to train the network, and three ones left – to check its accuracy. Fig. 13 shows the table with input data.

At first, it was used an unidirectional network trained using back-propagation algorithm (newff (P, newff (P, T, [S1 S2 ... S (NI)], {TF1 TF2 ... TFNI}, BTF, BLF, PF, . IPF, OPF, DDF). Settings of the NN are used the default namely:

- The number of layers is equal to 2.
- The number of neurons at each level (Si) and transient response of this level (TFi), default = «tansig».
- The backprop network training function (BTF), default = «trainlm».
- Backprop weight/bias learning function, default = «learnqdm».
- Performance function, default = «mse».

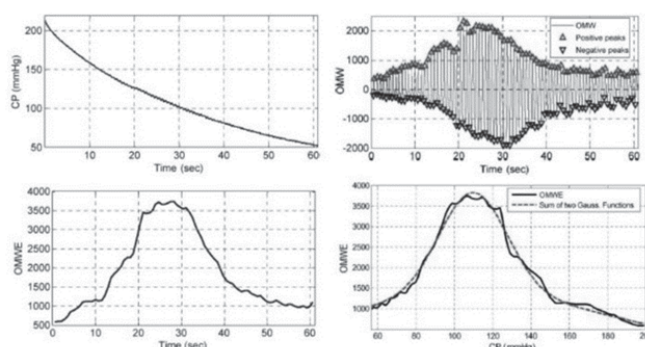

Fig. 12. Steps of an alternative method of signal processing

Train <27x7 double>							
	1	2	3	4	5	6	7
1	18.5791	19.8079	26.5565	31.8054	31.0862	24.8642	22.4815
2	24.0253	21.9294	32.2905	34.0363	31.8277	25.3945	27.5089
3	28.2206	26.7138	38.2434	28.6417	28.4403	25.8915	22.8474
4	23.0140	27.3247	35.6597	26.9900	24.7842	25.5878	18.1984
5	23.4112	24.6914	39.5898	24.5933	24.1070	26.1836	21.7084
6	20.1262	23.2761	40.1979	22.6809	22.3558	22.0643	17.3477
7	19.2490	24.2081	43.1331	18.0260	15.0351	22.0663	13.2546
8	15.8553	24.2467	39.1961	15.2485	15.7977	18.6044	12.2574
9	14.5867	18.9717	39.2847	15.2005	11.7730	17.6482	11.4882
10	14.8460	15.8430	14.4680	14.4580	11.5280	16.4190	16.2610
11	15.7450	16.7270	15.4990	15.4290	12.4670	17.1650	17.2750
12	16.6040	17.6030	16.5190	16.3430	13.3640	17.8830	18.2690
13	17.4280	18.4590	17.4170	17.1490	14.2040	18.6210	19.2090
14	18.2790	19.2770	18.2590	17.9750	15.0830	19.3420	20.1360
15	19.0880	20.0480	19.1000	18.8260	15.9400	20.0320	21.0730
16	19.8630	20.8410	20.0090	19.6600	16.7860	20.7430	21.9220
17	20.6330	21.6990	20.8690	20.4220	17.6560	21.4370	22.8030
18	21.3650	22.5490	21.7560	21.1890	18.5510	22.1290	23.7320
19	84.9800	80.1000	74.2400	85.9600	86.4500	85.4700	83.5200
20	90.3500	85.9600	79.6100	94.7500	94.2600	91.3300	92.7900
21	93.7700	92.7900	85.4700	102.5600	102.0700	95.7200	100.1200
22	97.6800	98.1600	89.8600	109.8800	107.9300	100.6100	105.9800
23	105	102.0700	94.7500	116.7200	115.2500	104.5100	113.7900
24	109.3900	106.9500	99.1400	123.5500	120.1400	108.9100	119.1600
25	113.7900	112.8100	102.5600	128.4400	124.5300	111.8400	124.5300
26	117.7000	116.2300	107.4400	133.8100	128.9300	114.2800	130.3900
27	121.6000	119.6500	110.8600	139.1800	135.7600	119.1600	136.2500

Fig. 13. Input data for neural network

By analyzing the results obtained using this NN it can be concluded that it does not give enough accurate results, i.e. error is ± 8 mmHg and ± 9 mmHg for SBP and DBP respectively. So, there is a need for more careful choice of network parameters (because default values of parameters mentioned above are not always equal to those which they adopt in fact) as well as studying the influence of each of these parameters on the precision of the results. The accuracy of values achieved using the NN is calculated as the square of the difference between NN result and the actual value obtained by the BMP. These values have been averaged for three results of training network, for each result were held five retests of the NN. For calculated data the standard deviation has been found (i.e. the mean of all root-mean-square deviations – RMSD) and also the maximum of all RMSD got with help of the NN. Thus, the first parameter shows the average error, and the second – the maximum possible error of the NN. Tables I - VI show the influence of changes in various parameters on the result of the NN (for each subsequent table option is selected the previous one corresponding to the value of the lowest standard deviation).

TABLE I. INFLUENCE OF THE NUMBER OF LAYERS

Number of layers	2		3		4		5	
	SBP	DBP	SBP	DBP	SBP	DBP	SBP	DBP
Average	24	65	32	87	40	78	27	62
Maximum	110	230	112	393	124	254	75	192

Number of layers	6		7		8		9	
	SBP	DBP	SBP	DBP	SBP	DBP	SBP	DBP
Average	25	61	35	53	53	25	61	35
Maximum	79	209	143	189	255	79	209	143

TABLE II. INFLUENCE OF THE NUMBER OF NEURONS

	2.2.2.2		5.2.2.2		4.2.2.2		5.5.2.2	
	SBP	DBP	SBP	DBP	SBP	DBP	SBP	DBP
Average	20	45	32	21	20	45	32	21
Maximum	51	137	137	88	51	137	137	88

	5.4.2.2		5.2.8.2		5.2.5.2		5.2.3.2	
	SBP	DBP	SBP	DBP	SBP	DBP	SBP	DBP
Average	29	43	38	44	28	48	37	41
Maximum	106	202	79	182	70	165	128	114

	5.2.2.5		5.1.1.1		5.1.2.2		5.1.1.2	
	SBP	DBP	SBP	DBP	SBP	DBP	SBP	DBP
Average	30	30	54	51	30	34	20	29
Maximum	68	70	175	336	93	105	61	71

TABLE III. INFLUENCE OF THE TRANSFER FUNCTION

	tansig		compet		hardlim		hardlims	
	SBP	DBP	SBP	DBP	SBP	DBP	SBP	DBP
Average	21	27	24	28	21	27	24	28
Maximum	110	230	112	393	110	230	112	393

	logsig		postlin		purelin		radbas	
	SBP	DBP	SBP	DBP	SBP	DBP	SBP	DBP
Average	21	34	15	44	21	34	15	44
Maximum	79	209	143	189	79	209	143	189

	satlin		satlin		satlins		softmax	
	SBP	DBP	SBP	DBP	SBP	DBP	SBP	DBP
Average	24	24	38	43	33	38	43	33
Maximum	195	195	110	230	112	110	230	112

TABLE IV. INFLUENCE OF THE TRAINING FUNCTION

	trainb		trainbfg		trainbr		trainc	
	SBP	DBP	SBP	DBP	SBP	DBP	SBP	DBP
Average	24	36	30	26	24	36	30	26
Maximum	61	95	64	62	61	95	64	62

	traincgb		traincgf		traincgp		traincga	
	SBP	DBP	SBP	DBP	SBP	DBP	SBP	DBP
Average	27	33	29	60	27	33	29	60
Maximum	52	83	83	234	52	83	83	234

	traingdm		traingdx		trainlm		trainoss	
	SBP	DBP	SBP	DBP	SBP	DBP	SBP	DBP
Average	28	29	29	28	28	29	29	28
Maximum	106	72	87	74	106	72	87	74

	trainr		trainrp		trains		trainscg	
	SBP	DBP	SBP	DBP	SBP	DBP	SBP	DBP
Average	380	148	18	31	380	148	18	31
Maximum	389	157	74	97	389	157	74	97

TABLE V. INFLUENCE OF THE PERFORM FUNCTION

	mae		mse		msereg		sse	
	SBP	DBP	SBP	DBP	SBP	DBP	SBP	DBP
Average	25	26	11	26	25	26	11	26
Maximum	87	49	32	75	87	49	32	75

TABLE VI. INFLUENCE OF THE LEARNING FUNCTION

	learncon		learnrd		learnrdm		learnh	
	SBP	DBP	SBP	DBP	SBP	DBP	SBP	DBP
Average	14	27	19	31	14	27	19	31
Maximum	34	56	47	103	34	56	47	103

	learnhd		learnis		learnnk		learnlv1	
	SBP	DBP	SBP	DBP	SBP	DBP	SBP	DBP
Average	31	32	20	31	32	20	24	25
Maximum	153	119	69	153	119	69	106	72

	learnlv2		learnos		learnrp		learnrpn	
	SBP	DBP	SBP	DBP	SBP	DBP	SBP	DBP
Average	12	32	19	27	27	28	11	35
Maximum	87	74	96	87	64	73	389	157

After the network setting and research the influence of its parameters on the results we have designed the NN with the following parameters:

- Five layers.
- The number of neurons in the i-th level (Si) is 5, 2, 2, 2, 2 for 1 to 5 levels respectively and transient response corresponds to the default one (i.e. «tansig» – hyperbolic tangent).
- The backprop network training function (BTF) – «trainbr» (regularization bayesian).
- Backprop weight/bias learning function (BLF) – «learncon» (conscience bias learning function)
- The network performance function (PF) – «msereg».

Consequently, when calculating BP parameters using this NN the average error values can be $\pm 3 \text{ mmHg} \pm 5 \text{ mmHg}$ for SBP and DBP respectively that are quite better results in compare with the first NN (default parameters) and the MAA (Table VII).

TABLE VII. PARAMETERS OF ALGORITHMS

Algorithm	BP parameters	Error, mmHg	Maximum error, mmHg
Maximum amplitude algorithm	SBP	$\pm 4,5$	9
	DBP	± 8	17
Neural network	SBP	± 3	5
	DBP	± 5	7

VI. CONCLUSIONS

The designed BPM provides blood pressure measuring during air inflation to the arm cuff. Fixing pressure values during inflation of the cuff ensures comfortable process conditions for patient as well as allows to take measurements several times in a row because the cuff does not disrupt blood flow through the artery. The two main ways to calculate SBP and DBP are given. Using of neural networks for signal processing allows to adapt an algorithm to the particular patient and get results with required precision. The two types of NN are considered. The NN with configured settings gives results that are more accurate then default one as it more adapted to actual measuring parameters.

REFERENCES

[1] World Health Organization, "Global atlas on cardiovascular disease prevention and control", 2011, 166 p.

[2] American College of Obstetricians and Gynecologists, "Hypertension in pregnancy. Task Force on Hypertension in Pregnancy", 2013, 100 p.

[3] O'Brien E., Beevers D.G, *ABC of hypertension*, London: BMJ Books, 2007.

[4] Lackland D.T., Weber M.A, "Global burden of cardiovascular disease and stroke: hypertension at the core", *The Canadian journal of cardiology*, № 31 (5), 2015, pp. 569–571

[5] Julian S.T., Pallavi A., "Adaptive Non-invasive Blood Pressure Measurement", *International Journal on Recent and Innovation Trends in Computing and Communication*, vol. 3, i. 4, pp. 2447-2451

[6] Majid M., "Blood Pressure Estimation using Oscillometric Pulse Morphology", 2012, 133 p.

[7] Forouzanfar M., Hilmi R. Dajani, Voicu Z., "Feature-Based Neural Network Approach for Oscillometric Blood Pressure Estimation", 2011, vol. 60, no. 8, pp. 2786-96

[8] P. D. Baker, J. A. Orr, D. R. Westenskow, and T. P. Egbert, "Method for determining blood pressure utilizing a neural network," U.S. Patent 5 339 818, Aug. 23, 1994.

[9] S. Narus, T. Egbert, T. Lee, J. Lu, and D. Westenskow, "Noninvasive blood pressure monitoring from the supraorbital artery using an artificial neural network oscillometric algorithm," *J. Clin. Monit.*, vol. 11, no. 5, pp. 289–297, Sep. 1995.

[10] S. Colak and C. Isik, "Blood pressure estimation using neural networks," in *Proc. IEEE Int. Conf. CIMS*, Boston, MA, Jul. 2004, pp. 21–25.

[11] Mohamad Forouzanfar, Hilmi R. Dajani, Voicu Z., Miodrag Bolic and Sreeraman Rajan, "Feature-Based Neural Network Approach for Oscillometric Blood Pressure Estimation", *IEEE transactions on instrumentation and measurement*, vol. 60, no. 8, Aug. 2011

[12] W. S. Sarle, "Neural Network FAQ, Periodic Posting to the Usenet Newsgroup comp.ai.neural-nets", Jun. 1, 2010.

[13] G. Dorffner and G. Porenta, "On using feedforward neural networks for clinical diag-nostic tasks," *Artif. Intell. Med.*, vol. 6, no. 5, pp. 417–435, Oct. 1994.

[14] N.A. Korenevskiy, E.P. Popechitelev, "Biotechnicheskie sistemy medicinskogo nasnacheniya", pp. 184-190

[15] Kushakovskiy M.S., *Gipertonicheskaya bolezni*. Saint-Petersburg, 1995.